



# CGA 351

## Panametrics zirconium oxide oxygen analyzer

### Features

- Fast, easy one-point calibration
- Low maintenance
- Measures oxygen from 0.1 ppm to 100 percent; can measure oxygen in reducing gases
- Fast response (90 percent of step change in less than 2 seconds)
- Extremely stable sensor operation
- Months of trouble-free service; calibration checks or adjustments seldom required; one-point calibration is sufficient for entire range from ppm to percent oxygen
- Accuracy increases at low oxygen concentrations

### Trace O<sub>2</sub> applications

This full-featured oxygen analyzer is typically used in applications such as:

- Air separation plants
- Glove boxes
- Semiconductor manufacturing processes
- Heat treat and metallurgical processes
- Glass and ceramic research
- Inert gas purity
- Blanket gas monitoring
- Medical research
- Gas blending

### Special applications

- Welding atmospheres
- Gas generators
- Air/fuel mixtures



Wall mount version of CGA 351

### How it works

Sample gas enters the inlet port through a needle valve and flows into a ceramic inlet tube. It then flows through the annular space between the inlet tube and the inside of the zirconium oxide oxygen sensor, then out through the outlet port and a flowmeter. When there are no combustibles present in the sample gas, the analyzer measures total oxygen. When combustibles are present, a platinum-based catalyst at the end of the ceramic tube ensures that the sample reaches equilibrium before contacting the inner electrode. It is therefore possible to measure either oxygen excess or deficiency in air/fuel mixtures.

The zirconium oxide sensor is heated and closely controlled at 1292°F (700°C). As the sample contacts the inner electrode of the heated sensor, an electrical signal is generated. The signal is proportional to the logarithm of the ratio of the oxygen concentration in the sample gas to the oxygen concentration in a reference gas contacting the outer electrode. The electronics displays O<sub>2</sub> in ppm or percent. It also displays other parameters including O<sub>2</sub> sensor millivolts and sensor temperature in °F or °C. Ambient air is used as the reference gas on the outside of the electrochemical cell.

### Panametrics zirconium oxide oxygen analyzer

The CGA 351 zirconium oxide oxygen analyzer uses an advanced zirconia sensor to accurately determine oxygen content in process gases. Microprocessor-based electronics allow measurements from ppm levels to 100 percent oxygen.

### Applications and uses

The CGA 351 zirconium oxide oxygen analyzer is suitable for monitoring and/or controlling high purity gas streams or atmospheres such as in air separation, heat treating, ceramic manufacturing and other processes. For dirty or wet gas applications, a suitable sampling system may be required.

# CGA 351 specifications

## Performance

### Accuracy

0.2 ppm from 0 to 10 ppm or  $\pm 2\%$  of reading

### Repeatability

$\pm 1\%$  of reading

### Response time

Less than 2 seconds for 90% step change

### Stability

Less than 3% of reading per year

### Pressure effect

Less than 0.2% of reading per mm Hg

### Sample flow rate influence

Per 40 cc/min flow change at 400 cc/min

0.2 ppm from 0 to 10 ppm or

2% of reading

### Background gas variation effect

Sample gas must be clean, dry and free of combustibles.

For best results used same background gas for calibration. Standard factory calibration is 5 ppm O<sub>2</sub> in N<sub>2</sub>.

## Operating

### Measurement range

- Standard factory setup is 0 to 10 ppm for 4 to 20 mA output. Field selectable for any portion of the range from 0.1 to 10 ppm O<sub>2</sub>

- 0.1 ppm to 100% O<sub>2</sub>

- The digital panel meter is software configurable to display the following parameters:

- Oxygen (ppm or %)
- Temperature (°F or °C)
- Sensor (mV)
- CJC temperature (°F or °C)

- Field selection of autorange

### Output ranges

0/4 to 20 mA, 0 to 2 V

## Alarm circuits

- Dual alarm contacts
- Contact rating 2 A, 28 VDC, SPDT, fail-safe

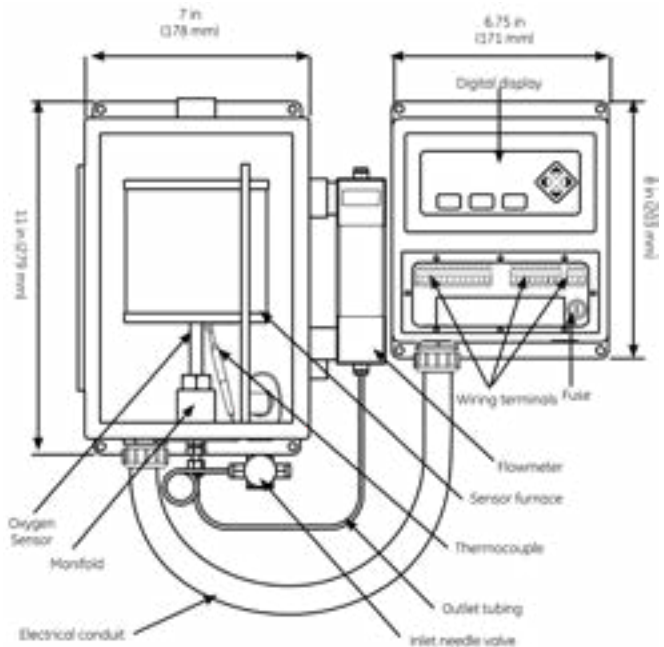

Wall mount version of CGA 351. Dimensions in inches (mm).

## Communications

Standard RS232 serial port, PanaView™ read only

## Sample requirements

- Sample flow: 400 cc/min ( $\pm 40$  cc/min recommended)
- Sample inlet pressure: 1 to 10 psig
- Sample outlet (vent) pressure: 1 atmosphere

## Ambient requirements

- Relative humidity: 90% maximum
- Temperature range: -13°F to 122°F (-25°C to 50°C)

## Power

100/115/220/240 VAC, 50 to 60 Hz, 900 W maximum

## Line-voltage influence

$\pm 10\%$  nominal line voltage

## Fuse

4 A, 250 V, TD, 5 x 20 mm

## Materials contacting sample gas

316 stainless steel, ceramic and platinum

## Connections

- Sample inlet and outlet: 6 mm compression or 1/4 in compression tube fitting
- Electrical analyzer and D/O unit: 1/2 inch conduit

## Dimensions

- Sensor enclosure: 7.0 in x 11.0 in (178 mm x 279 mm)
- Electronics enclosure: 6.75 in x 8.0 in (171 mm x 203 mm)

## Warm-up time

- 45 minutes nominal
- Calibration at alarm or control level with certified mixtures of O<sub>2</sub> in N<sub>2</sub>

## European compliance

Complies with EMC Directive 2014/30/EU, LV Directive (overvoltage category II, pollution degree

## Ordering information

Record selected option in blank indicated at bottom of form.

### CGA 351 zirconium oxide oxygen analyzer

#### Power

- 1 100 VAC, 50 to 60 Hz
- 2 115 VAC, 50 to 60 Hz
- 3 220 VAC, 50 to 60 Hz
- 4 240 VAC, 50 to 60 Hz

#### Package

- 1 Wall mount
- 2 Rack mount

#### Connections

- 1 1/4 in tube fitting
- 2 6 mm tube fitting

#### Special

- 0 None
- S Special (consult factory)

CGA 351: \_ \_ \_ Use this number to order product

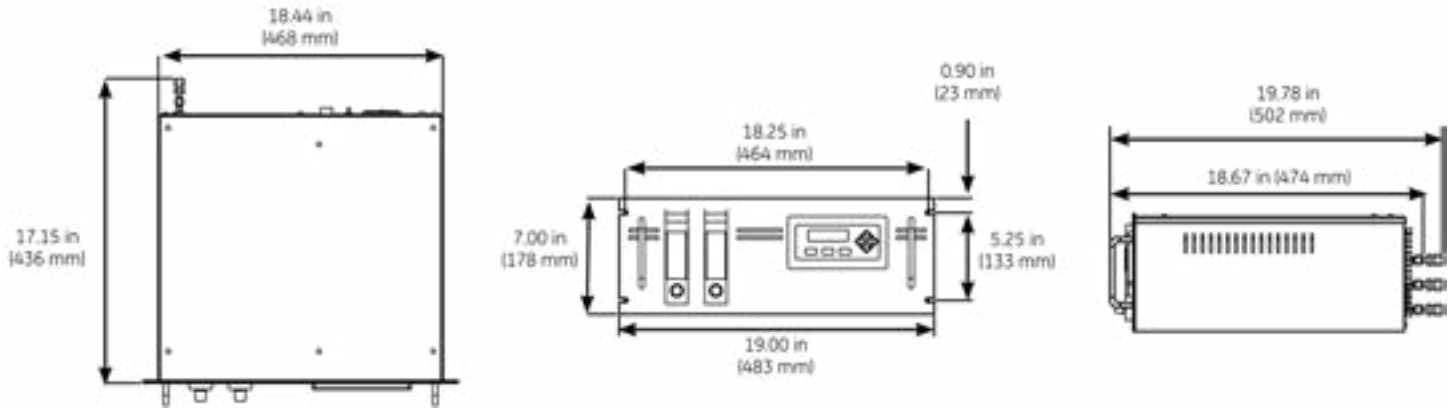

Rack mount version of CGA 351

Panametrics, a Baker Hughes Business, provides solutions in the toughest applications and environments for moisture, oxygen, liquid and gas flow measurement. Experts in flare management, Panametrics technology also reduces flare emissions and optimizes performance.

With a reach that extends across the globe, Panametrics' critical measurement solutions and flare emissions management are enabling customers to drive efficiency and achieve carbon reduction targets across critical industries including: Oil & Gas; Energy; Healthcare; Water and Wastewater; Chemical Processing; Food & Beverage and many others.

Join the conversation and follow us on LinkedIn  
[linkedin.com/company/panametricscompany](https://www.linkedin.com/company/panametricscompany)

**Baker Hughes** 