

ADAPT 3701/44 Aeroderivative Monitor

Bently Nevada* Asset Condition Monitoring

Advanced Distributed Architecture Platform Technology - ADAPT

GE's Bently Nevada* Advanced Distributed Architecture Platform Technology, or ADAPT 3701, is a family of compact, high performance safety and machinery protection and condition monitoring solutions. ADAPT products are targeted at specific assets and applications, and excel at the intensive signal processing necessary to identify early indicators of machine failure modes long before an alarm.

Description

The 3701/44 ADAPT Aero Monitor is specifically designed for protection and condition monitoring on aeroderivative gas turbines and their driven equipment. The 3701/44 is optimized for the signal processing required on aero gas turbines such as 1X order tracking of casing vibration at multiple rotor speeds, narrow band high order filtering, multiple bandpass filters on a single sensor and combustion dynamic pressure pulsation measurement. The 3701/44 with dual redundant (DR) processor modules is designed for protection on critical rotating machinery.

The 3701/44 has a rugged industrial design allowing it to be skid mounted close to the machine and reduce installation wiring. Its compact small size provides more mounting options compared to traditional rack based solutions. It is capable of accepting a wide array of sensor types, including eddy current proximity probes, charge-coupled accelerometers, Integrated Circuit Piezoelectric Sensors (IEPE), velocity, acceleration, dynamic pressure, and magnetic speed pick-ups.

ADAPT 3701 is configured and validated with Bently Nevada Monitor Configuration (BNMC) software. BNMC is a simple and powerful configuration and validation environment used for the 3701/44 Aero Monitor. It is ordered separately and is required for operation.

The 3701/44 Aeroderivative Monitor is a self-contained device that is ordered with a single part number for either a simplex or duplex terminal base and is made up of the following major components:



3701/44 Simplex



3701/44 Duplex

Part	Quantity Required in each 3701/44
3701 Simplex Terminal Base	1
3701 Processor Module	1
3701 Input Module	1 or 2
3701 Output Module	1 or none

Part	Quantity Required in each 3701/44
3701 Duplex Terminal Base	1
3701 Processor Module	2
3701 Input Module	1 or 2
3701 Output Module	1 or none



3701/44 Overview

The 3701/44 is a robust, compact, self-contained 12-channel device with sophisticated signal processing capability and with a form-factor suitable for distribution close to machinery. The ADAPT Aero has a modular construction that allows field changing of components and is fully-configurable. It combines protection and condition monitoring (CM) in a single package. With the ability to define measurements and alarms within the monitor itself, it can act as a stand-alone protection and CM system. There is no need for any interaction with external software to trigger or control the monitor during operation.

The 3701/44 DR Machinery Dynamics Monitor is a compact, field mountable, vibration protection system that utilizes dual redundant processor modules.

In the DR version, each processor module is identically configured and redundantly digitizes and processes all sensor inputs, executes identical logic, and each processor module independently drives separate alarm relays.

3701 Digital Communications

The 3701/44 has two independent Ethernet physical RJ45 connections per CPU for digital communication with Bently Nevada software products hosted on network computers and plant automation systems. It uses a proprietary Ethernet protocol for communicating with System1* Evolution software and the BNMC configuration software.

The 3701/44 includes two Ethernet ports per CPU which provide Ethernet TCP/IP communications capabilities. Standard industrial protocols are:

- Modbus TCP/IP
Modbus over Ethernet is available for connection to HMI's, unit control systems, or other plant automation equipment. The 3701 can only be configured as a server.
- Ethernet Global Data (EGD)
EGD is a GE protocol used on Mark VI and Mark Vie controllers and by GE Programmable Automation Controllers and certain 3rd party automation equipment.

3701/44 System Description

The 3701/44 monitor is powered by single or dual redundant external +24 V DC power. It consists of four main physical components: the terminal base

(single or dual), one or two processor modules, one or two input modules, and an output module.

The terminal base is the mounting platform for the monitor. The different modules install into the terminal base and two pluggable field wiring termination blocks plug into the terminal base. Sensor wiring terminates on the wiring blocks and terminations for discrete inputs (Reset, Trip Multiply, etc.) terminate directly on the base but on the opposite side from sensor wiring.

The processor module is the monitor's CPU. It is the center of the logic and signal processing for the monitor.

There are two terminal base configurations:

- A simplex base, which contains 1 CPU processor card
- A duplex base which contains 2 CPU processor cards.

The use of 2 processor cards allows for redundancy for all the dynamic measurements; both processors have access to all signal channels from each input module.

The input modules are the interface to the sensors. Each input module type covers multiple sensor varieties but due to the number of sensor types there are different input modules. The input modules condition the analog sensor signals for delivery to A/D conversion on the processor module. The input modules are simple, reliable, analog circuitry but with a simple microcontroller (outside the protection path) to provide diagnostics and fault detection on each module. Buffered transducer outputs are provided at a multi-pin Dsub connector on each input module. An accessory cable is available to fan the buffered outs to BNC or ADRE 408 Dspi compatible connectors.

The output modules are for monitor outputs such as relay contacts or 4- 20 mA analog outputs. At the current time only the 8-Channel Relay Output Module is available. It contains 8 programmable SPDT relays and a dedicated monitor Protection Fault (OK) Relay. Relay logic is created in the BNMC software using the graphical logic editor.

Processor Module

The processor module, or CPU module, performs A/D conversion, digital signal processing, alarm and logic processing, and communications to GE Bently Nevada software and plant automation systems. The CPU module employs sophisticated diagnostics and fault detection processing to enhance reliability, availability, and maintainability of the protection and monitoring system.

Input Modules

3701 Proximitor* Accelerometer* Aeroderivative (PAA) Input Module

The 3701 PAA input module is a 6-channel + Keyphasor/speed input module that interfaces to a variety of sensors such as: -24 Volt Proximitor sensors, -24 Volt 3-wire Accelerometers, Charge-Amplifiers, and differential output Aeroderivative Interface Modules used with charge-coupled hi-temp accelerometers or dynamic pressure sensors.

Any of the PAA's six channels (1 – 6) can be independently configured for one of the supported transducers. Each PAA supports one dedicated Keyphasor or speed measurement on channel 7 that is configurable for Proximitor sensors or magnetic pick-ups. A 2-wire, galvanically isolated, hi-impedance input is available for magnetic pick-up speed sensors. The isolated input eliminates potential ground loops that can occur when speed sensors are shared between the vibration system and other instrumentation.

3701 Proximitor Accelerometer Velomitor* (PAV) Input Module

The 3701 PAV input module is a 6-channel + Keyphasor/speed input module that interfaces to a variety of sensors such as: -24 Volt Proximitor sensors, -24 Volt 3-wire Accelerometers, Velomitor sensors, and constant current 2-wire sensors that are compatible with the -24 Volt 2-wire Velomitor interface.

Any of the PAV's six channels (1 – 6) can be independently configured for one of the supported transducers. Each PAV supports one dedicated Keyphasor or speed measurement on channel 7 that is configurable for Proximitor sensors or magnetic pick-ups.

3701 Positive (PoV) Input Module

The 3701 PoV input module is a 6-channel + Keyphasor/speed input module that interfaces to a variety of positively powered sensors such as: +24 V Proximitor sensors, +24 V Interface modules, and 2 wire IEPE sensors using 3.3 mA constant current.

Any of the PoV's six channels (1-6) can be independently configured for one of the supported transducers. Each PoV supports one dedicated negatively powered Keyphasor or speed measurement on channel 7 that is configurable for Proximitor sensors or magnetic pick-ups.

Output Modules

3701 8-Channel Relay Output Module

The 3701 8-Ch Relay Output Module provides 8 SPDT relay outputs or 4 "virtual" DPDT outputs and a dedicated Protection Fault relay. Relay logic is user programmable in the BNMC software using the graphical logic editor. The processor module operates on the relay logic to drive relay state.

The Protection Fault relay is a normally energized SPDT relay that will de-energize on fault conditions that can compromise the monitor's availability to protect machinery. The protection fault relay is similar to a traditional OK relay but certain conditions that do not compromise protection will not cause the Protection Fault relay to de-energize.

The relays are configured for Normally De-Energized (NDE) or Normally Energized (NE) in four banks of two relays each using a switch on the relay module.

Relay wiring terminates on the output module using pluggable connectors and exits on the opposite side of the monitor from the sensor inputs.

In dual redundant operation, processor module one drives relays 1, 3, 5, and 7 and processor module two drives relays 2, 4, 6, and 8. The relay alarm logic is identical. External connection to an Emergency Shutdown Device can use a 1oo2 or 2oo2 configuration depending on the user's needs. Users are recommended to perform a system analysis using functional safety methods (IEC 61511, IEC 61508 or ISA SP84) before selecting a voting scheme.

Terminal Base

3701 Simplex and Duplex Terminal Bases

The term "simplex terminal base" identifies, or distinguishes this type of terminal base as one with a single (simplex) processor module as opposed to a dual (or duplex) terminal base with two processor modules.

The 3701 simplex terminal base is the mounting and installation component of the monitor. It supports a single processor module, one or two input modules, and an output module.

The terminal base mounts to a bulkhead, or enclosure or wall sub-panel using the four mounting holes at the corners of the base. Mount vertically for optimal convection cooling.

The duplex terminal base is similar in function to the simplex terminal base except that it has two CPU processor modules instead of one. The extra CPU module allows the user to use the two input modules redundantly. Both CPU modules have access to all the signal channels from each of the input modules.

Terminal base features:

- Two pluggable terminal blocks provide sensor wiring terminations that are individually marked for the sensor wire type. The termination blocks can be removed for wiring ease or maintenance work and, when installed, are fixed in place with a locking mechanism.
- A dedicated connection terminal for single point connection to system earth.
- A single point earth connection switch to separate physical (chassis) earth from system common (instrument earth) to enable system common connection to an external intrinsic safety earth.
- Primary and secondary connectors for single or redundant +24 V DC power input.
- Six discrete inputs (DI) for dedicated dry contact DIs: Trip Multiply, Alarm/Relay Inhibit, Latch Reset, Special Alarm Inhibit, Run Mode, and IP/Account reset. There are two sets of these six inputs on the dual terminal base.

Channel Types, Sensors, and Measurements

The 3701/44 Aero Monitor supports a set of standard channel types and the common sensors used with those channel types as well as custom configurable sensors. Support for sensor types is dependent on input module type as listed in tables located below in this datasheet section. Each channel type has default measurements that can be enabled or disabled and each channel type can have user customizable nX and bandpass measurements added to the channel and then customized to the application.

The 3701/44 can have up to 12 vibration input channels (Six per input module) and 2 Keyphasor/Speed inputs (One per input module). The monitor supports the channel types listed here:

- Acceleration
- Dynamic Pressure
- Radial Vibration
- Thrust Position
- Velocity
- Keyphasor/Speed

The aeroderivative core section of an aero gas turbine is typically monitored by high-temperature charge-coupled accelerometers that connect to a package mounted interface module consisting of

a charge amplifier, signal conditioning, and both acceleration and velocity analog outputs. The acceleration and velocity inputs are treated as their respective channel types in the aero monitor.

Channel Type support by Input Module

Input Module	Channel Types
PAA Channels 1-6	Acceleration Dynamic Pressure Radial Vibration Thrust Position Velocity
PAA Channel 7	Keyphasor/Speed (Proximitors, single and multi-event, or Isolated Mag pickup, single and multi-event)
PAV Channels 1-6	Acceleration Dynamic Pressure Radial Vibration Thrust Position Velocity
PAV Channel 7	Keyphasor/Speed (Proximitors, single and multi-event or Mag pickup, single and multi-event)
PoV Channels 1-6	Acceleration Dynamic Pressure Radial Vibration Thrust Position Velocity
PoV Channel 7	Keyphasor/Speed (Proximitors, single and multi-event or Mag pickup, single and multi-event).

PAA and PAV channels 1–6 can also be configured to support an additional Keyphasor input provided it is a single event per revolution, less than 5000 rpm, and uses a Proximitor sensor. This cannot be done with the PoV module.

Input Module compatibility with acceleration inputs

Input Module	Accelerometer or Accelerometer Interface Module
PAA	155023-01 High Freq 200g Accel I/F Module 23733-03 Accel I/F Module 24145-02 High-Freq Accel I/F Module 330400 100 mV/g Accelerometer 330425 25 mV/g Accelerometer 330450 High Temp Accelerometer 350501 Acceleration Charge Amplifier 350900 High Temp Velocity & Acceleration 49578-01 Accel I/F Module 86497 RR Accel I/F Module 86517 Aero Accel I/F Module (Differential Input) Custom
PAV	155023-01 High Freq 200g Accel I/F Module 23733-03 Accel I/F Module 24145-02 High-Freq Accel I/F Module 330400 100 mV/g Accelerometer 330425 25 mV/g Accelerometer 330450 High Temp Accelerometer 350501 Acceleration Charge Amplifier 49578-01 Accel I/F Module Custom
PoV	GSI 122, 124 and 127 Galvanic Interface Unit TP100 Commtest Accelerometer TP500 Commtest Accelerometer 200350 Accelerometer 200355 Accelerometer 786-500 Wilcoxon Accelerometer 626B02PCB Accelerometer HS-170 Hansford Accelerometer HS-100F series Hansford Accelerometer CMSS-2100 SKF Accelerometer 351M35 PCB Accelerometer

Input Module compatibility with velocity inputs

Input Module	Velomitors and interface modules
PAA	350900 HTVAS (Velocity) 86497 RR I/F Module (Velocity) 86517 Aero I/F Module (Velocity - differential input) Custom
PAV	330500 Velomitor 330525 Velomitor XA 190501 Velomitor CT 330750 High Temp Velomitor 330752 High Temp Velomitor 330505 Low Freq Velocity Sensor 330530 Radiation Resistant Velomitor Custom
PoV	HS-160 Velocity Sensor

Input Module compatibility with Proximitors sensors

Input Module	Proximitors Sensor
PAA or PAV	3300XL 8 & 11 mm 3300XL NSV 3300 RAM Proximitors
PoV (Keyphasor)	3300 5 & 8 mm 3300 16 mm HTPS 7200 5, 8, 11, 14 mm 3000 (-24 Volt) Custom

Input Module compatibility with dynamic pressure inputs

Input Module	Dynamic Pressure Sensor
PAA	3-Wire (Com/Sig/-24VDC) 350500 DPCA or Modified 86517 I/F
PAV	3-Wire (Com/Sig/-24VDC) 350500 DPCA or Modified 86517 I/F
PoV	2-wire PCB 121A21 2-wire PCB 121A44 2-wire PCB 121A22

Measurements

Each channel type has a set of default measurements typical of the channel type. In addition, user customizable nX vectors and bandpass measurements may be added to each channel.

The number of measurements that can be added and enabled depends on the signal processing capability of the processor module. There is no limitation, other than processor performance, to the number of measurements that can be added to a single channel or across all channels. A performance calculator in the BNMC software provides feedback during the configuration process on performance margin as measurements are added or removed and their attributes modified.

Default Measurements by Channel Type		
Input Type	Meas.	⁽²⁾ Configurable Attributes
RV	Direct	Full scale range Units (mils or μm peak-peak or rms) High pass corner frequency Low pass corner frequency High pass filter order (1,2,4,6, or 8 th) Low pass filter order (1, 2, 4, 6, or 8 th) Clamp value (amplitude)
	1X	Full scale range Keyphasor association Integer or non-integer order in increments of 0.1x from 0.1x to 100x (phase not valid for non-integer orders). Units (mils or μm peak-peak or drms) Clamp value (amplitude and phase)
	2X	Full scale range Keyphasor association Integer or non-integer order in increments of 0.1x from 0.1x to 100x (phase not valid for non-integer orders). Units (mils or μm peak-peak or drms) Clamp value (amplitude and phase)
	Gap	Low Pass Corner Frequency Clamp Value (Volts)
Accel, Velocity	Direct	Full scale range Units (English or metric, peak or rms) High pass corner frequency Low pass corner frequency High pass filter order (1,2,4,6, or 8 th) Low pass filter order (1, 2, 4, 6, or 8 th) Clamp value (amplitude) Integrated
	1X	Full scale range Keyphasor association Integer or non-integer order in increments of 0.1x from 0.1x to 100x (phase not valid for non-integer orders). Units (English or metric, peak or drms) Clamp value (amplitude and phase) Integrated

	2X	Full scale range Keyphasor association Integer or non-integer order in increments of 0.1x from 0.1x to 100x (phase not valid for non-integer orders). Units (English or metric, peak or drms) Clamp value (amplitude and phase) Integrated
	Bias	Low Pass Corner Frequency Clamp Value (Volts)
Thrust	Position	Full scale range Units (mils or μm peak-peak or rms) Low pass corner frequency Clamp value (amplitude)
	Gap	Low Pass Corner Frequency Clamp Value (Volts)
Dynam Press.	Pressure	Full scale range Units (psi or mbar peak-peak, dpp or rms) High pass corner frequency Low pass corner frequency High pass filter order (1,2,4,6, or 8 th) Low pass filter order (1, 2, 4, 6, or 8 th) Clamp value (amplitude)
	Band-pass	Full scale range Units (psi or mbar peak-peak or rms) High pass corner frequency Low pass corner frequency High pass filter order (1,2,4,6, or 8 th) Low pass filter order (1, 2, 4, 6, or 8 th) Clamp value (amplitude)
Prox Speed	Bias	Low Pass Corner Frequency Clamp Value (Volts)
	Speed	Top Scale Clamp Value
Mag Pickup Speed	Gap	Low Pass Filter Frequency Clamp Value (Volts)
	Speed	Top Scale Clamp Value

Additional Measurements by Channel Type		
Input Type	Meas.	⁽¹⁾ Configurable Attributes
RV, Thrust, Dynam Press, Accel, Velocity	Band-pass	Full scale range Units (English or metric, peak to peak or rms) High pass corner frequency Low pass corner frequency High pass filter order (1,2,4,6, or 8 th) Low pass filter order (1, 2, 4, 6, or 8 th) Clamp value (amplitude)
	nX	Full scale range Keyphasor association Integer or non-integer order in increments of 0.1x from 0.1x to 100x (phase not valid for non-integer orders). Units (English or metric, peak to peak or drms) Clamp value (amplitude and phase)
	Amp. Extract	Full scale range Units (English or metric, peak to peak or rms) Clamp value (amplitude) Associated Spectrum Center Frequency Bandwidth
	Spec. Band	Full scale range Units (English or metric, peak to peak or rms) Clamp value (amplitude) Associated Spectrum Start Frequency Stop Frequency

- (1) Technically feasible configurations depend on the interaction between many factors. Certain selections may not be feasible. Use the BNMC software to create an off-line configuration to determine technical feasibility.
- (2) The default measurement attributes can also be customized.

Waveforms and Spectral Data

Acquisition of multiple synchronous and asynchronous waveforms can be configured for each 3701 channel in the BNMC software. These waveforms are used as the data source for extraction of measurements that require spectral data such as nX vectors and peak extractions.

Waveform configuration for spectral data consists of f_{max} and the number of lines in the spectral data.

Asynchronous spectral waveforms:

F_{max} can be set between 10 Hz and 40 kHz in 12 discrete steps. F_{min} is always at 0 Hz.

The number of spectral lines can be set from 12.5 to 3200 in 12 discrete steps.

Synchronous spectral waveforms:

Number of samples per revolution can be set from 8 to 4096.

Number of revolutions per waveform can be set from 1 to 1024.

Amplitude Extractions

An Amplitude extraction is the amplitude at a user configured center frequency and with a user configured bandwidth. The band around the center frequency is limited in size and can range from a single spectral line (bucket) closest to the configured center frequency, to the center spectral line plus 5 lines on each side (11 total buckets).

The source data for amplitude extractions are asynchronous spectrums.

Multiple amplitude extractions can be configured on a single channel and across multiple channels.

Spectral Bands

Spectral bands are user configured with a start and a stop frequency and return the average energy in the band.

The source data for spectral bands are synchronous and asynchronous spectrums using either enveloped spectral or ordinary spectral data.

Multiple spectral bands can be configured on a single channel.

Applications for spectral bands and other signal processing features are described in the Applications section of this datasheet.

Alarming and Setpoints

Alert and Danger over and under alarm setpoints can be created for each measurement individually as well as configurable alarm attributes such as enable/disable, alarm time delay (ATD), and latching/non-latching.

In addition, the alarming attributes (enable/disable, ATD, and latching/non-latching) can be set independently on the Alert and Danger alarms on the same measurement.

Relay logic is created in the graphical relay logic editor in BNMC software by mapping the enabled alarms to OR and AND gates to drive a relay.

Individual relays can be configured as latching/non-latching or enabled/disabled independently (or in addition to) the settings on the measurement alarms.

Network Operation

The processor module supports two Ethernet RJ45 physical connections located on the terminal base. The two connectors are termed Net A and Net B and each has its own configurable IP address. All configuration and interface to Bently Nevada software and communication using an industrial protocol is using one or both of these connections.

Display and HMI Options

GE Bently Nevada offers System 1* Basic as a simple, low cost, easily installed, and light footprint HMI. System 1* Basic is part of the System 1* Evolution platform and offers a subset of System 1* Evolution functionality to provide a basic operator display.

The Modbus TCP or EGD industrial protocols can be used to serve data to an HMI where users can build display environments using standard 3rd party HMI software.

Bently Nevada Configuration Software (BNMC)

BNMC software is necessary to configure and verify the 3701/44 Machinery Dynamics Monitor.

BNMC is simple configuration software with a nominal price that is used for monitor configuration. It also has snapshot viewing of timebase waveforms (including Keyphasor/Speed) and spectrums to support commissioning and setup of the 3701 and sensor instrumentation system. Bently Nevada Monitor Configuration software will run on most Windows desktop or notebook computers and is designed and fully tested for operation on Microsoft® Windows® 7 and 8.1 (32 bit and 64 bit) and Microsoft Windows 2008 and 2012 Server (64 bit).

Language support at the current time is English version operating systems with keyboard preference set to English.

BNMC is ordered separately from the monitor hardware. See the spares section in the Specifications portion of this datasheet for the part number.

System 1 Evolution Connectivity

3701 monitors connect to System 1 Evolution and support current value and time-based data collection of all static values, waveforms, and spectral data. This includes System 1's full suite of plots and tools for conditioned monitoring and asset management.

Applications

This section describes selected applications where 3701 function and feature offers particular benefits.

Dual Redundant Protection

A typical dual redundant protection only application has these basic elements:

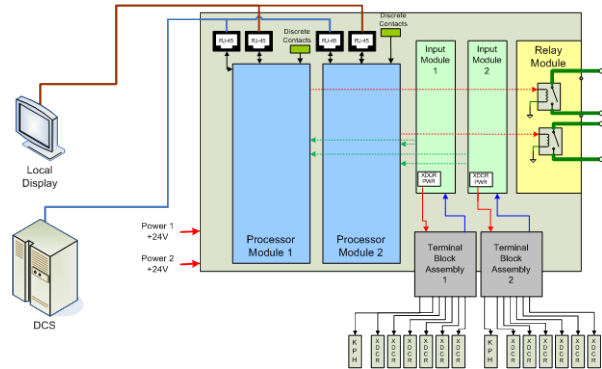

- Each processor module processes all sensor and Keyphasor input signals and has communication (Ethernet) connections only to the controls and automation system.
- Each processor is configured the same and executes identical logic.
- Processor module 1 drives relays 1, 3, 5, and 7. Processor module 2 drives relays 2, 4, 6, and 8. The same alarm logic is used for each relay pair (1, 2), (3,4) etc..
- An external shutdown system connects to relay pairs and votes 1oo2 or 2oo2 depending on application requirements. (The 1oo2 configuration is for SIL 2 applications.)
- The dedicated protection fault relay is driven by a protection fault in either of the processor modules and is driven if one processor module is removed.
- If redundant sensors are required, they can be voted 2oo2 or 1oo2 in the 3701 processor modules. SIL 2 applications require voting the 3701 relays 1oo2 in an external ESD but the sensor alarm voting in the 3701 processors provides the 2oo2 vote.
- System configuration can be varied in a number of ways to meet different reliability requirements. Redundant sensors can be used partially or entirely. Non-redundant sensor

points, such as XY radial shaft vibration probes, on the same bearing can also be split between input modules.

- Redundant industrial protocols can operate independently from each processor module to automation and control systems.

Dual Redundant Protection with a System 1 Connection

This optional configuration operates the same as described above but Processor Module 1 connects to System 1 using one of its Ethernet ports. Cyber security is the key design element that must be addressed in this configuration.

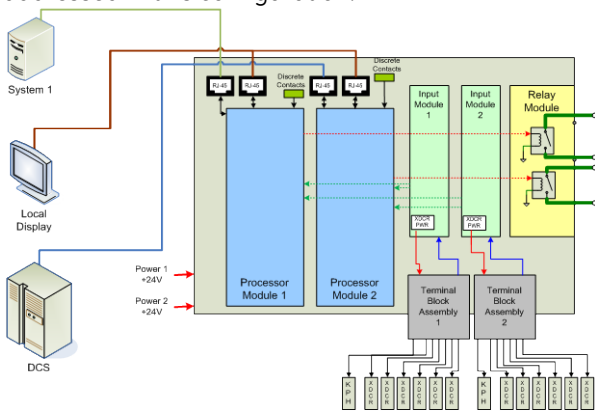

Radial Shaft Vibration, Axial Position, and Casing Vibration

3701 supports the standard industry measurements for these applications but, in addition, users can create custom measurements on these channels using spectral bands, bandpass timebase measurements, amplitude extractions, nX measurements, integrated and non-integrated, and rms or peak measurements.

Detection of certain mechanical, aerodynamic, and hydraulic, faults can be enhanced by improved measuring capability. For example, on an axial compressor there may be increased sub-synchronous axial vibration at the onset of a surge condition – a bandpass timebase measurement or synchronous spectral band measurement on an axial position probe can enhance detection of this specific fault mode.

Roller Element Bearings

Use spectral bands to focus on bearing fault frequencies. (nX measurements can also be used but the spectral band allows customizing the

bandwidth to the bearing fault frequency response whereas the nX measurement is narrow band.)

Outer Race Ball Pass (ORBP)	A spectral band using synchronous enveloped or non-enveloped data can be set around the expected ORBP
Inner Race Ball Pass (IRBP)	A spectral band using synchronous enveloped or non-enveloped data can be set around the expected IRBP
Cage	A spectral band using synchronous enveloped or non-enveloped data can be set around the expected cage frequency
Ball Spin 1X	A spectral band using synchronous enveloped or non-enveloped data can be set around the expected ball spin 1X frequency
Ball Spin 2X	A spectral band using synchronous enveloped or non-enveloped data can be set around the expected ball spin 2X frequency
Overall and non-REB fault frequencies	Set one or more bandpass measurements to look at overall vibration at frequencies where rotor, casing, or structural vibrations are expected. nX measurements can also be used for rotor related vibration.
HF band	Set a spectral band using enveloped synchronous or asynchronous data sources on a broader high frequency band to detect low level impact events. (A simple bandpass with an appropriately set high pass filter can be configured in addition.)

Gear Boxes

There are many types of gear boxes with correspondingly different vibration monitoring needs. This short section is intended only to highlight some particular features of the 3701 system.

Feature	Description
Gear Mesh (GM) 1X, 2X, or 3X	Set a synchronous spectral band, or an nX measurement (or both) on the 1X, 2X, and 3X GM. For

	each gear set.
Gear Mesh Side Bands	If you know the fundamental frequency of an expected side band based on your gear kinematics then you can set a synchronous spectral band on a specific sideband.
Enhanced measurements from Radial Vibration Proximitors	For API 613 gearboxes where XY radial vibration probes are typically specified you can set the GM related spectral bands described above as well as nX's based on hi and low speed shaft Keyphasors.
Enhanced measurements from Thrust Position Proximitors	For API 613 gearboxes where axial position probes are typically specified. Axial vibration can be measured by setting bandpass filtered or nX measurements in addition to the conventional thrust position measurement.

Gas Turbine Combustion Dynamic Pressure

Spectral bands and/or amplitude extractions as well as bandpass filtered timebase measurements can be configured to selectively monitor the different tones produced by pressure pulsations in combustion turbines.

Specifications

3701/44 Monitor Power Requirements

Input Voltage

Min: 18VDC
Max: 36VDC

Current

2.3 amps max current (Simplex)
3.0 amps max current (Duplex)

Inrush Current

3.0 amps max inrush less than
5 mS (Per processor card)

Supply must be 2006/95/EC Low Voltage Directive compliant for CE installations.

Supply must be Class I, Div 2 or Class I, Zone 2, (CL2 SELV), compliant for hazardous area Installations.

3701/44 Processor Module Specifications

Inputs

Max: 12 dynamic signals and 2
Keyphasor/speed signals

Signal/Noise Ratio

110db @ 102.4 ksps

A/D Conversion

Sigma- Delta 24 bit.

Bandwidth

0.5 to 40Khz

Outputs

Two Independent Ethernet ports

Net A: 10/100 BaseT
Net B: 10/100 BaseT

Buffered Signal Outputs

15 pin DSUB connector, available
accessory cable for BNC and SMC
options.
550 ohm output impedance

LEDs

Module OK LED

Indicates when the module is
functioning properly.

Protection Fault LED

Indicates that the monitor has
experienced a fault that is affecting
protection

User Inhibit LED

Indicates that there has been a user
initiated inhibit of alarming functionality

Attention LED

Indicates a condition on the monitor
has occurred that may require action

Danger LED

Indicates a Danger condition

Alert LED

Indicates and Alert condition

KPH 1 OK LED

Indicates that Keyphasor signal 1 is
triggering.

KPH 2 OK LED

Indicates that Keyphasor signal 2 is
triggering.

NetA

Indicates that Network A has a valid link

TX/RX A

Indicates that network traffic is flowing
on Network A

Net B

Indicates that Network B has a valid link

TX./RX B

Indicates that network traffic is flowing
on Network B

PWR 1 OK

Indicates that the first power input is
functioning correctly

PWR 2 OK

Indicates that the second power input
is functioning correctly

Accuracy

Direct pk or rms

Within $\pm 0.5\%$ of full-scale typical,
1.1% Worst Case

Bias

+0.4 V / -0.8 V typical, +0.8V / -
1.34 V worst case.

Tracking filters

nX tracking filters have a
bandwidth of 0.075X, where X is
the speed of the associated
speed channel.

Alarming

Setpoints

Over/under user configurable

Time Delay

100mS – 60 minutes

Latching

User configurable alarming or
relay latching

Input Impedance

All 3-wire Inputs (PAA & PAV)

Nominal input impedance is 10
k Ω .

2-Wire Input – PAA (Aeroderivative)

Nominal differential input
impedance is 99.8 k Ω .

2-Wire Input – PAV (Velomiters)

Nominal constant current is
3.3267 mA.

2-Wire Input – PAA - Speed channels (Isolated Magnetic Pickup)

32.08 k Ω when input signal is
below 30 Vpp, and a 9.98 k Ω
when above 30 Vpp

Speed Signal Inputs

Speed Range Dedicated Speed/Keyphasor Input

1 to 120,000 rpm

Speed Range Auxiliary Keyphasor Input

1 to 10,000 rpm

Speed Resolution

1 to 100 rpm ± 0.1 rpm
100 to 2000 rpm ± 1 rpm

Gap

± 8.2 mV typical
 ± 22.3 mV worst case

Phase Accuracy

± 1 degree up to 20 kHz for most
sensors*

Auto Threshold

Use for any input above 1 rpm for 1
event/resolution.

Manual Threshold

± 150 mV, user selectable from +3.5 to
-23.5 Vdc.

Hysteresis:

User selectable from 0.2 to 10 volts.

Signal Amplitude:

Minimum signal amplitude for trigger
is 2 volts peak-to-peak.

Note: Refer to Hazardous Area Special Considerations
Section for Maximum Magnetic Pickup amplitude
requirements for hazardous area applications.

* Phase accuracy on 2 wire sensors on the PAA input card
has ± 1 degree up to 500 Hz and ± 5 degree up to 3 kHz

Relay Output Specifications

Relay Type

Single Pole Double Throw (SPDT).
Normally Open (NO), Normally Closed
(NC), and Armature (ARM) contacts

Contact Ratings

5A/250 Vac/1500 VA Max.
5A/250 Vdc/150 VA Max.

Minimum Switching Current

12Vdc/100mA

Normally De-Energized (NDE) or Normally Energized (NE)

NDE/NE independently selectable for
Relays 1 – 4 and 5 – 8 using a switch on
the relay module.

Note: Refer to Hazardous Area Special Considerations
Section for Relay specifications when used in hazardous
area applications.

3701/44 Environmental Specifications

Indoor Use Only

Operating Temperature Range

-30 C to +65 C†
(-22 F to 149 F)

† If the 3701 is operated 100% at +65C, its life will be reduced to approximately 11 years. Any portion of the time it is operated below +65C or any convective airflow will increase its lifespan.

Storage Temperature Range

-40C to +85C
(-40 F to 185 F)

Relative Humidity

0% to 95% rH non-condensing
Operating and Storage

Vibration

5g @ 57-500 Hz.
IEC 60068-2-6

Shock

15g, 11ms

Altitude

< 2000 m (6,562 ft)

Pollution Degree

Pollution Degree 2

Installation Category

Category II

Physical

Simplex Base Dimensions

26.7 x 20 x 18.2 cm (10.5 x 7.87 x
7.15 in)

Simplex Weight

4.5 kg (9.9 lbs)

Duplex Base Dimensions

26.7 x 27.7 x 18.2 cm (10.5 x 10.9
x 7.15 in)

Duplex Weight

7.7 kg (17.1 lbs)

Mounting (Simplex and Duplex)

Bulkhead

4 mounting bolts or screws at
corners.

Compliance and Certifications

EMC

Standards

EN 61000-6-2
EN 61000-6-4

European Community Directives:

2004/108/EC

Electrical Safety

Standards

EN 61010-1

European Community Directives:

2006/95/EC Low Voltage

Cyber Security

Achilles Communications Certification Level1

Certification in process. Contact Bently Nevada)

Hazardous Area Approvals

For a detailed listing of country and product specific approvals, refer to the Approvals Quick Reference Guide (document 108M1756) located at the following website: www.GEmeasurement.com.

CSA/NRTL/C

Class 1 Div 2, Groups A-B-C-D; T4
AEx/Ex nA IIC T4 Gc
T4 @ -30 °C to +65 °C
Installed per drawing 100M0771
CSA 14.2712664

ATEX

 II 3G
Ex nA nC IIC T4 Gc
T4@ -30°C ≤Ta ≤ +65°C
SIRA 15ATEX4288X



IECEX

Ex nA nC IIC T4 Gc
T4@ -30°C ≤Ta ≤ +65°C
IECEX SIR15.0099X

Hazardous Area Special Considerations

- Power supplies must be Class I, Div 2 or Class I, Zone 2 compliant for hazardous area installations.
- Hazardous area installations require relay contact voltages below 30 Vac rms, or 30 Vdc to minimize hazard.
- Hazardous area installations require relay contact amperages below 5 Amps DC, or AC to minimize hazard.

- Hazardous area installations require relay contact power below 100 Watts DC, or 100 VA AC to minimize hazard.
- Hazardous area installations require inter-terminal base connectors to remain unused.
- Magnetic Pickup input amplitude must not exceed 60Vrms to minimize hazard.
- Reference 100M8172 section 3 for additional Hazardous Area restrictions and information regarding installation of the 3701/44 system.

For further certification and approvals information, visit the following website:

<http://www.GEmeasurement.com>

Ordering Information

For a detailed listing of country and product specific approvals, refer to the Approvals Quick Reference Guide (document 108M1756) located at the following website: www.GEmeasurement.com.

The 3701/44 can be ordered as an individual component or as part of a kit that may include other components than just the monitor. Ordering part numbers are provided below for both options.

Use these part numbers to order ADAPT solution kits for specific turbine types:

- **ADAPT_LM2500** Designed for the LM2500
- **ADAPT_LM6000** Designed for the LM6000

Use the 3701/44 part number below to order the aero monitor.

3701/44-AXX-BXX-CXX-DXX- EXX

A:	Redundancy	
	01	Simplex
	02	Duplex
B:	Input Module 1	
	00	None
	01	Prox/Accel/Velom
	03	Prox/Accel/Aero
	04	Positive Input Module
C:	Input Module 2	
	00	None
	01	Prox/Accel/Velom
	03	Prox/Accel/Aero
	04	Positive Input Module
D:	Output Module	
	00	None
	01	8 CH Relay Module

E:	Approvals	
	00	None (This does include the non-Hazardous area general safety certification)
	01	CSA
	02	ATEX/IECEX
	XX	Country specific

Spares

3701/44

	3701/44 Aeroderivative Monitor
177896-01	
	3701/44 Processor Module
177990-01	
	Prox Accel Aero (PAA) Module
177990-01	
	Prox Accel Aero (PAA) Module
105M6001-01	
	Positive Input (POV) Module
177897-01	
	3701 Output Relay Module
175794-01	
	3701 Simplex Terminal Base
178372-01	
	Duplex Terminal Base
177992-01	
	3701 Terminal Block – Standard
100M9465-01	
	BN Monitor Configuration SW DVD

Accessories

323314-01	Buffered Output cable 15 pin D-Sub to 7 SMA connectors. (SMA connectors work with the ADRE 408)
323314-02	Buffered Output cable 15 pin D-Sub to 7 BNC connectors
324343	Weatherproof Housing Kit
Bently_Manuals	Customer DVD containing all Bently Manuals, FWD, App Notes, and Install Guides in all available languages

Figures

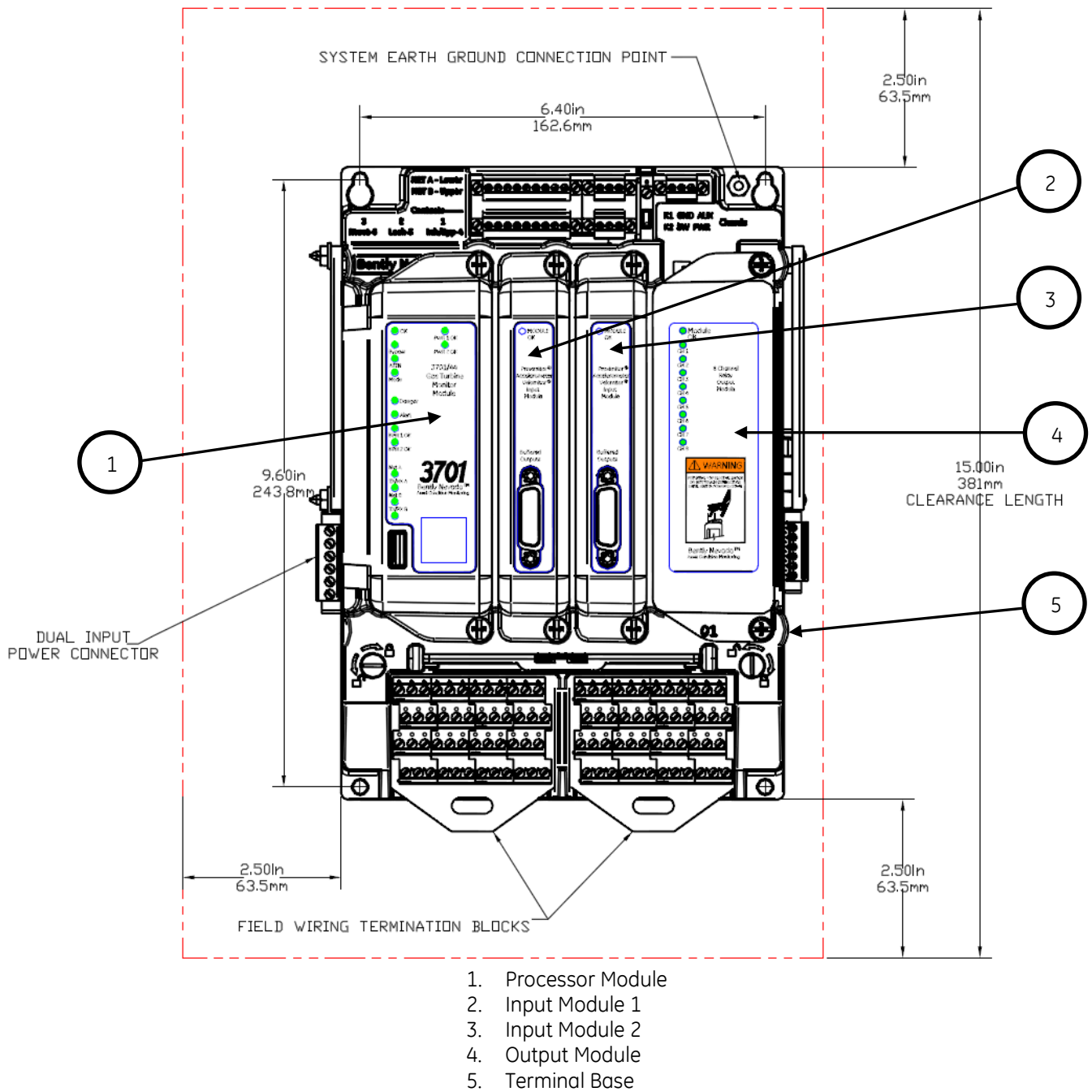

3701/44 Simplex Terminal Base Top View

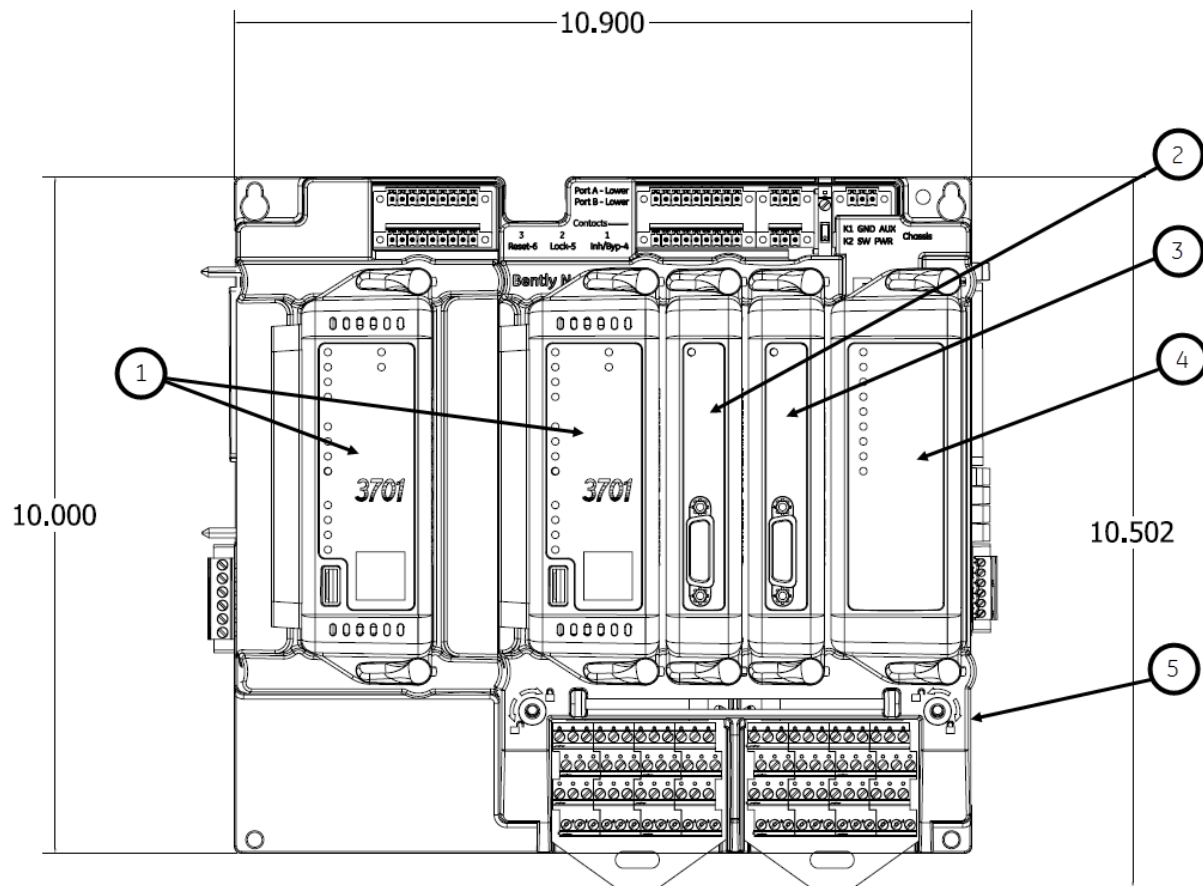

1. Processor Module(s)
2. Input Module 1
3. Input Module 2
4. Output Module
5. Terminal Base

3701/44 Duplex Terminal Base Top View

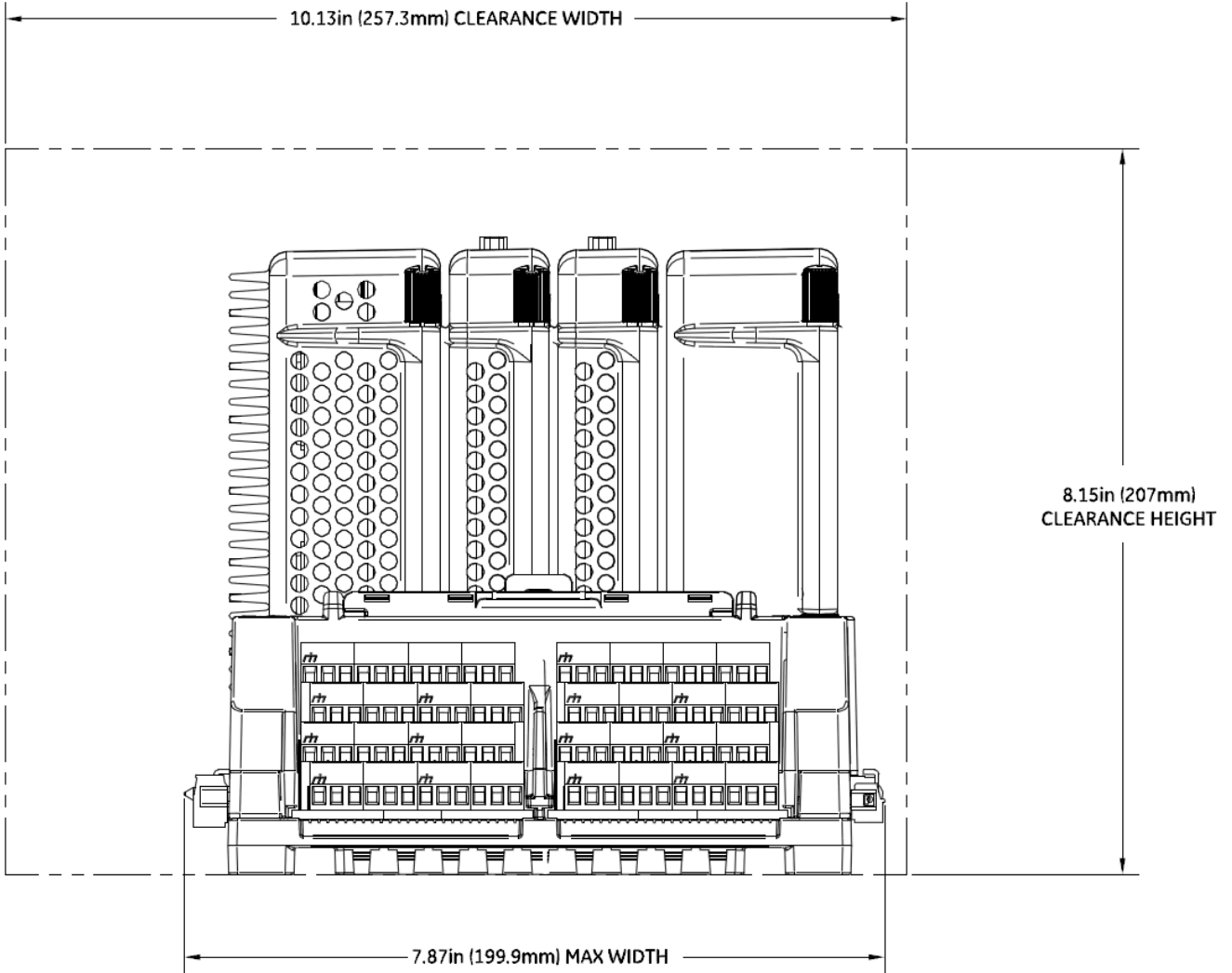

3701/44 Simplex Terminal Base Side View

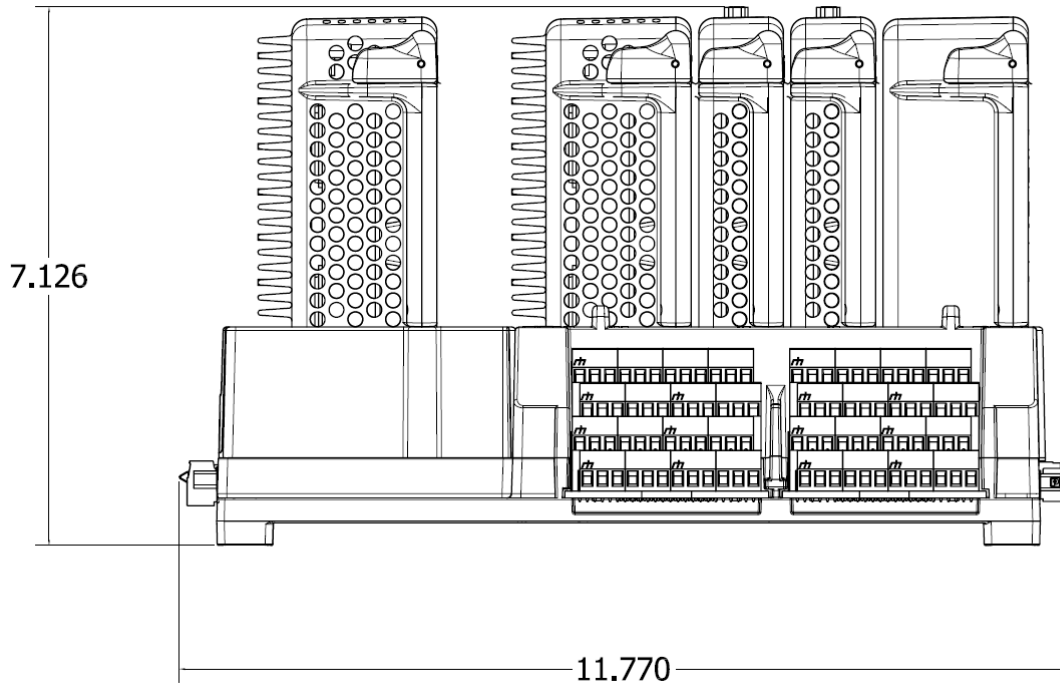

3701/44 Duplex Terminal Base Side View

*Denotes a trademark of Bently Nevada, Inc., a wholly owned subsidiary of General Electric Company.
Microsoft and Windows are registered trademarks of Microsoft Corporation.

© 2013 – 2016 Bently Nevada, Inc. All rights reserved.
This document is subject to change without prior notice.
Printed in USA. Uncontrolled when transmitted electronically.
1631 Bently Parkway South, Minden, Nevada USA 89423
Phone: 1-775.782.3611 Fax: 1-775.215.2873
www.GEmeasurement.com